



Touch Sensors

MPR121

12-pad touch sensor controller



A Touch Smarter

Freescale's MPR121 capacitive touch sensor controller simplifies design in the user interface of choice—touch sensing. Embedded developers require design simplicity and power conservation in a small form factor for compact system designs. The MPR121 solution replaces mechanical buttons, switches and other moving parts that typically wear out and are less reliable.

Freescale's MPR121 capacitive touch sensor controller is a CMOS-based state machine that simplifies designing numerous touch applications for lighting controls, mobile phones, MP3 players, remote controls and other low-power, hand-held, electronic products. The MPR121 operates with extremely low power at 29 μ A average supply current—contained in a small, low-profile 3 x 3 x 0.65 mm 20-lead QFN package.

The MPR121 next-generation device provides 12-electrodes with increased internal intelligence such as a flexible independent calibration feature, an increased electrode count, a hardware configurable I²C address, an expanded filtering system with debounce, and completely independent electrodes with built-in auto-configuration.

MPR121 Implementation Diagram

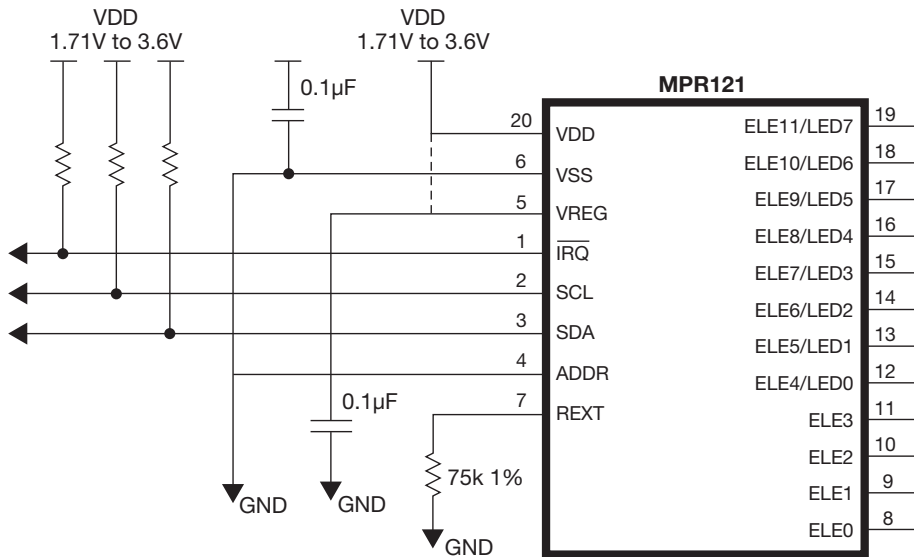

KITMPR121EVM Evaluation Kit in the Sensor Toolbox collection

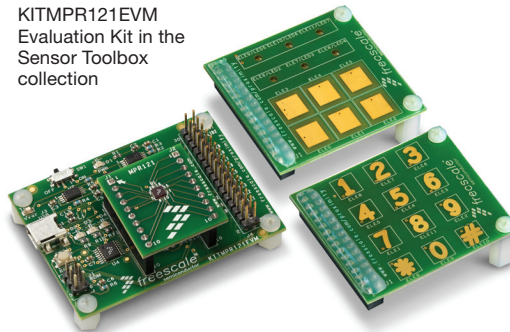

MPR121 Typical Applications

- PC peripherals
- MP3 players
- Remote controls
- Mobile phones
- Lighting controls



Key Features

- Supports up to 12 touch electrodes
- 1.71V to 3.6V operation
- 29 μ A average supply current
 - All twelve electrodes being monitored:
 - At 16 ms sample rate
 - At 64 ms response time
- Continuous independent auto-calibration for each electrode
- Separate touch and release trip thresholds for each electrode
 - Provides hysteresis and electrode independence
- Drives up to eight LEDs or provides up to eight logic I/Os in any combination
- 3 μ A maximum shutdown current
- I²C interface with IRQ output to advise electrode status changes
- 3 x 3 x 0.65 mm 20-lead QFN package
- -40°C to +85°C operating temperature range

Benefits

- Elimination of mechanical buttons
- Enhances reliability by eliminating mechanical wear and tear
- User interface controllers that manage multiple configurations
- Gives greater flexibility to product designers
- Reduces overall system cost

Freescale is a leading provider of pressure, inertial and touch sensors and has offered MEMS-based sensors for over 30 years. The sensor ICs complement Freescale's broad portfolio of ZigBee® technology, microcontrollers, microprocessors, digital signal processors, analog ICs and development tools to offer system solutions to customers.

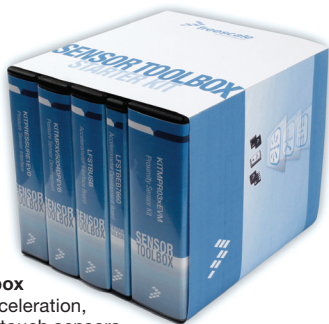

Sensor Toolbox

Evaluating acceleration, pressure and touch sensors has never been so easy.

Freescal Touch Sensor Product Feature Comparison

Feature	MPR03x	MPR121	Benefit
Capacitance Sensing			
High dynamic range	●	●	Measures electrodes from 1 pF to 2000 pF from the same device
Independent electrode configuration		●	Even in a single design, electrodes can vary in shape and size using a single device
Automatic configuration		●	Automatic independent setup for each electrode
Automatic reconfiguration		●	Customizable reconfiguration if baseline falls outside of range
Two-stage filtering system	●	●	Allows for simple data conditioning through averaging filter
Configurable sample rate	●	●	Sampling rate can vary between 1 ms and 128 ms
Touch Sensing			
Increasing and decreasing thresholds	●	●	Prevents bounce on touch recognition by providing hysteresis
Touch and release threshold IRQ	●	●	Touch and release are both reported by interrupt assert
Baseline tracking system	●	●	Maintains baseline by filtering out touch signals
Bi-directional baseline tracking system		●	Independent baseline tracking for positive and negative capacitance changes
Baseline filter delay		●	Filtering speed can be reduced for applications requiring fast response time and long-term baseline averaging
Stuck key removal baseline tracking		●	Stuck keys are detected and calibrated out with customizable system
Proximity Sensing			
Proximity sense mode	●		Detects proximity by combining electrodes as a separate configurable mode
Proximity sensing pseudo electrode		●	Detects proximity by combining electrodes as a pseudo electrode allowing for simultaneous proximity and touch detection
Proximity detect IRQ	●	●	Proximity detection is reported by interrupt assert
GPIO/LED			
Eight shared LED driving pins		●	Electrodes can be multi-purpose as touch sensor or GPIO LEDs
GPIO extender		●	If all pins are not used as electrodes, remainder can be simple GPIO extenders

Development Tools

Part Number	Description
KITMPR121EVM	Evaluation board as part of the Sensor Toolbox collection to demonstrate key touch sensor features

Documentation

Part Number	Description
MPR121	Data sheet presenting the specifications for this product
AN3889	Application note describing the MPR121 capacitance sensing settings
AN3890	Application note describing the MPR121 capacitance sensing filtering and timing
AN3891	Application note describing the MPR121 touch sensing baseline system
AN3892	Application note describing the MPR121 touch sensing jitter and false touch rejection
AN3893	Application note describing the MPR121 proximity sensing
AN3894	Application note describing the MPR121 LED driver system
AN3895	Application note describing the MPR121 serial communication

Learn More: For more information about Freescale products, please visit www.freescale.com/touch.