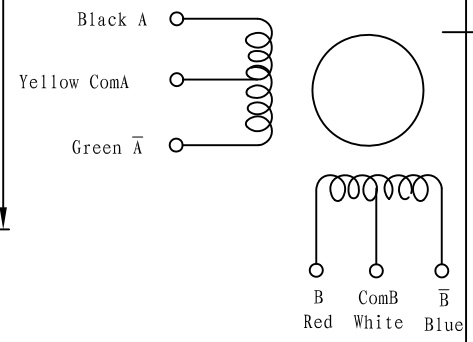

DIAGRAM
(Unipolar)



Label

1.8° Stepper Motor
LDO-57STH76-1006A
121127 LDO MOTORS

Items	Specs	Items	Specs
Phase Number	2 phases	Step Angle	1.8° ±5%
Rated Voltage	8.6 VDC	Rated Current	DC 1.0 A / Phase
Resistance(20°C)	8.6±15% Ω / phase	Inductance	14±20% mH / Phase
Holding Torque	≥13.5 Kg-cm	Detent Torque	0.6 Kg-cm REF.
Rotate Direction	ACBDA CW	MAX Starting PPS	1500 PPS
MAX slewing PPS	≥2500 PPS	Insulation Resistance	≥100 MΩ (DC 500V)
HI POT	AC600V/1mA/1S	Insulation Class	Class B
Rotor Inertia	480 g.cm ²	Weighth	1.2 Kg REF.

REV	ECN NO	Description	Made by	Approve	Date
A	---	New Release	Danny	J. B.	11/27/12
			LDO MOTORS CO.,LTD Hybrid Stepper Motor LDO-57STH76-1006A		
Des.	Check	Appr.	Date	Factory Code	page